

COSBER

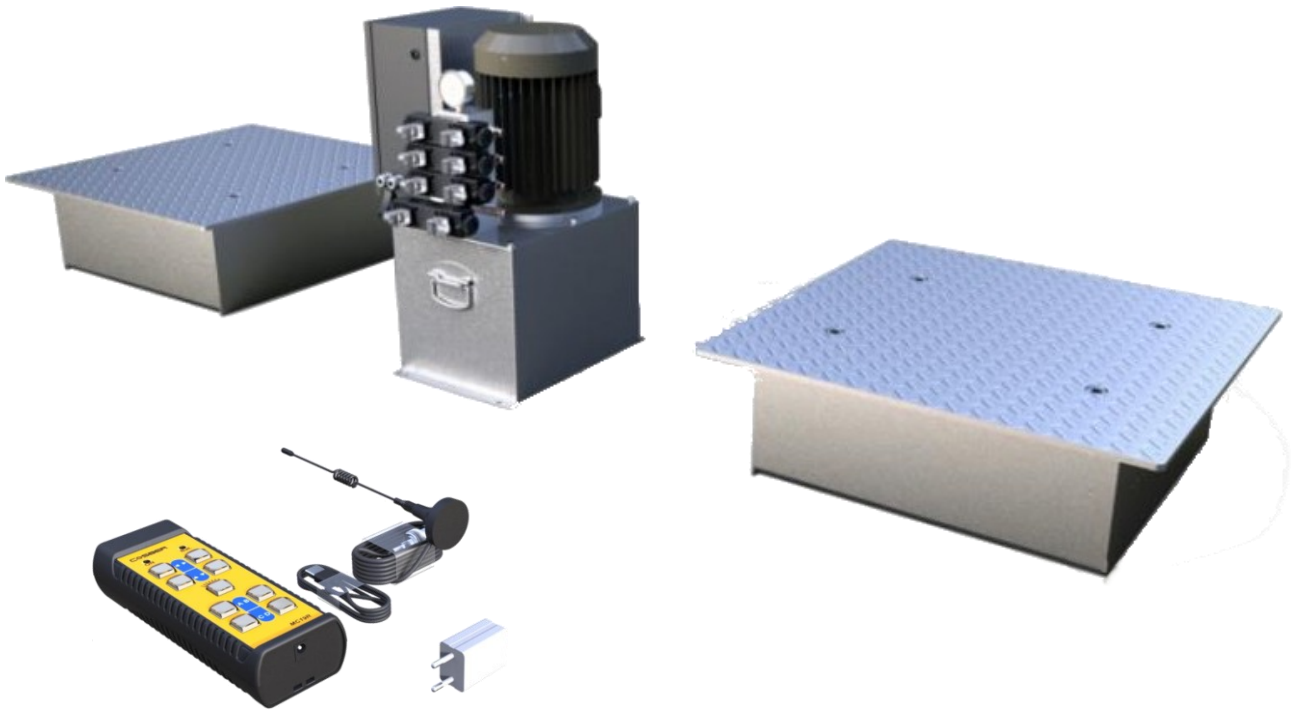

INFOSHEET

Truck Play Detector COSBER C-PD Series



Tuck Play Detector COSBER C-PDT Series

C-PD refers to the model series of various joint play testers that meet the requirements of different testing organizations.

The individual configuration options, due to the modular structure, allow configuration according to the ideas and expectations of each customer.

All joint play testers comply with the European Directive 2014/45/EU.

PLAY DETECTOR

DESCRIPTION:

- Hot-dip galvanized test bench
- Robust and simple design
- Low-wear and maintenance-friendly design
- All moving parts are equipped with grease fittings
- Handy wireless remote control with integrated LED lamp
- Multi-directional test sequence
- Fits into all common foundations
- Optionally available automatic centering according to test sequence
- Optionally available built-in trays for standard construction (above-ground test plates) or floor-level construction (underfloor test plates)
- Optionally available hydraulic hose sets in different lengths.

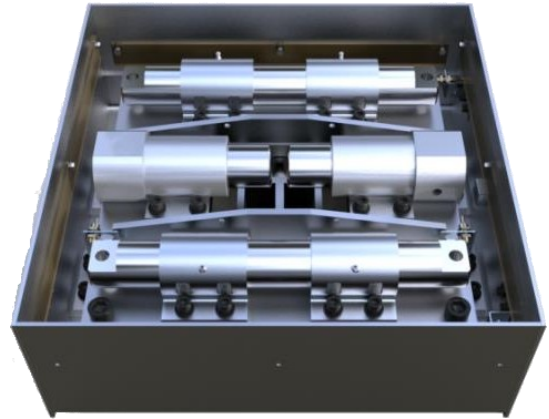

Robust construction



Hydraulic unit

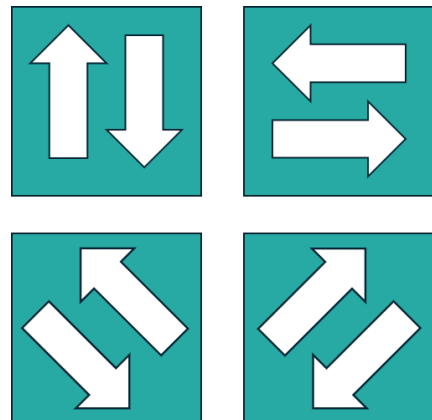

8 test directions

SPECIFICATIONS:

Model	C-PD72	C-PD72 XL
Max. override load / axle	18000 kg	
Max. wheel load	9000 kg	
Max. force	30 kN	
Travel path of the test plate	100 mm	
Test speed	5 – 15 cm/s	
Required hydraulic oil	30 Liter HLP46	
Max. operating pressure	120 bar	
Dimensions of test plate (LxWxH)	750 x 750 x 14 mm	750 x 900 x 16 mm
Dimensions of drive unit (LxWxH)	590 x 590 x 215 mm	
Dimensions foundation (LxWxH)	610 x 610 x 250 mm	
Hydraulic unit dimensions (LxWxH)	550 x 510 x 700 mm	
Power	4,0 kW	
Power supply	AC 3Ph x 400V / 50 Hz	
Weight net / gross	620 / 680 kg	640 / 700 kg

OPTIONS

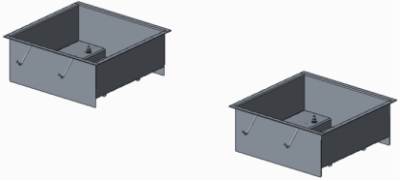
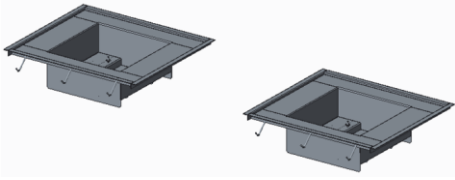
Description	Picture
Built-in trays for standard construction (Above-ground test plates)	
Built-in trays for floor-level construction (Underfloor test plates)	
Hydraulic hose set 4x2m	
Hydraulic hose set 4x5m	
Hydraulic hose set 4x8m	

