

COSBER



INSTALLATION GUIDE

CAR Brake Tester

COSBER C-BTC Series

CONTENT

| | | |
|-------|---|----|
| 1 | General | 3 |
| 1.1 | Important notes | 3 |
| 1.2 | Safety notes | 3 |
| 1.2.1 | Beware of electric shocks. | 3 |
| 1.2.2 | Keep away from the rotating rollers! Risk of crushing can lead to injury and death..... | 4 |
| 1.2.3 | Installation note | 4 |
| 2 | Equipment installation | 4 |
| 2.1 | Preparations..... | 4 |
| 2.1.1 | Examination of parts..... | 4 |
| 2.1.2 | Inspection of the pit..... | 5 |
| 2.1.3 | Foundation frames..... | 6 |
| 2.1.4 | Installation location | 7 |
| 2.1.5 | Power and wiring requirements | 8 |
| 2.2 | Brake tester installation. | 9 |
| 2.2.1 | Adjustment of brake tester height..... | 9 |
| 2.2.2 | Cable duct | 10 |
| 2.2.3 | Lifting the brake tester..... | 10 |
| 2.2.4 | Fixing the brake tester | 11 |
| 2.3 | Installation of control box..... | 12 |
| 2.3.1 | Wall mounting..... | 12 |
| 2.3.2 | Installation of column | 14 |
| 2.4 | Installation of Analog-Display | 16 |
| 2.4.1 | Wall mounting..... | 17 |
| 2.4.2 | Column..... | 18 |
| 3 | Control box | 19 |
| 3.1 | Control box description. | 19 |
| 3.2 | Electric diagram | 21 |

| | | |
|-------|---------------------------------------|----|
| 3.3 | Electrical connection..... | 21 |
| 3.3.1 | Connecting the main power cable | 21 |
| 3.3.2 | Connecting the brake test bench | 22 |
| 3.3.3 | Connecting to a PC..... | 26 |
| 4 | Analog-Display..... | 27 |
| 4.1 | Analog-Display description | 27 |
| 4.2 | Electrical connection..... | 28 |
| 4.2.1 | Connecting the power cable | 28 |
| 4.2.2 | Connection the signal cable..... | 29 |
| 5 | Start | 30 |
| 5.1 | Installation checklist | 30 |
| 5.2 | Check by starting..... | 31 |
| 6 | Software system | 31 |
| 6.1 | Installation of the program | 31 |
| 7 | Notes | 34 |

1 General

1.1 Important notes

- First, thank you for choosing this product.
- This manual is included with the product. For efficient use of the system, users should read the instructions carefully before installation and keep them for future reference and maintenance purposes.
- The specifications and information provided in this manual are for informational purposes only. They may be updated periodically without notice.
- This product should only be used for its intended purpose. It should never be used for any other purpose. The manufacturer is not liable for damages resulting from improper use of the product.
- Please strictly adhere to the operating guidelines and instructions and remember that the system requires regular maintenance.
- This product should only be operated and used by specially trained personnel.
- Personnel not employed by our company are not authorized, without our consent, to disassemble or modify the product or use it for any purpose beyond its intended detection function.
- In cases where the product is damaged due to human factors or force majeure (earthquakes, floods, etc.), the user must promptly take effective remedial action and notify our company as soon as possible.

1.2 Safety notes

Be sure to read carefully before installing the device and pay attention to the following tips.



NOTIFY USERS OR NEARBY PERSONS OF ANY DANGEROUS INFORMATION, AND ALWAYS INFORM OF ANY DANGEROUS CONSEQUENCES AND PREVENTIVE MEASURES.

WARNING!

| Reminder | Probability of occurrence | Risk severity |
|----------------|---------------------------|---------------------------|
| Danger | Direct danger | Personal injury and death |
| Warning | Danger | Personal injury |
| Hint | Danger | Minor injury |

1.2.1 Beware of electric shocks.



1.2.2 Keep away from the rotating rollers! Risk of crushing can lead to injury and death.



1.2.3 Installation note

All necessary configuration settings and calibration of the sensors should be conducted exclusively by Cosber technical personnel or approved partners of Cosber.

2 Equipment installation

2.1 Preparations

2.1.1 Examination of parts

Contents of the minimum configuration package:

- One brake tester (including the signal wire and power cable for the gear motor connected to the control box)

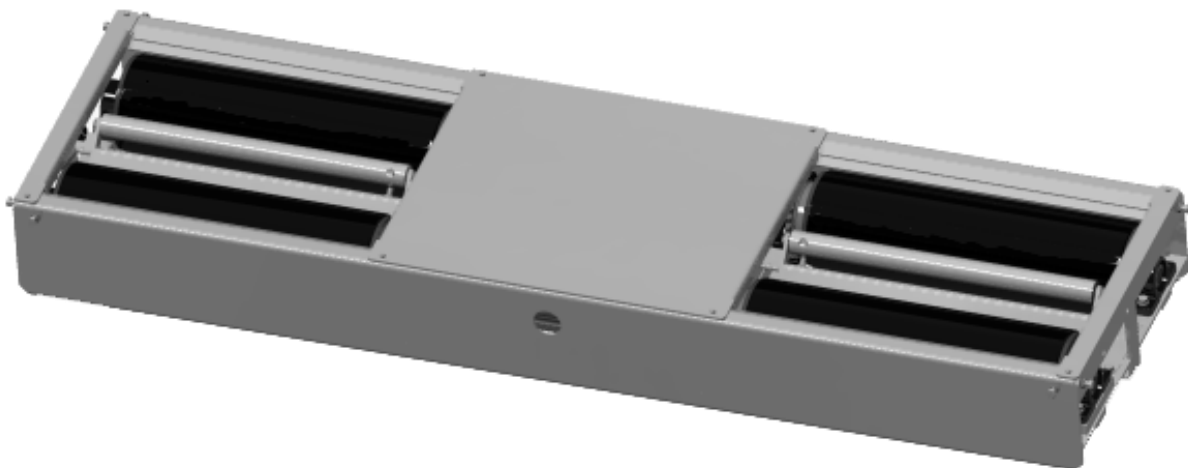

- One control box (including the power cable connected to the main power switch)



- Please verify contents according to the packing list.
- Please make sure that all the equipment is intact, and the user should take timely and effective remedial measures and notify the Company immediately if there is any damage caused by error or force majeure factors (e.g., earthquakes and floods).

2.1.2 Inspection of the pit

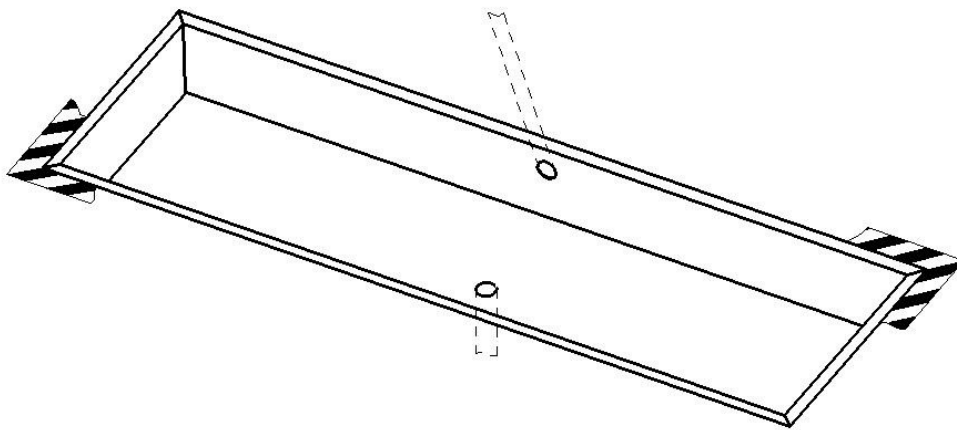

- COSBER C-BTC 2x:

Cable conduit $\varnothing 80\text{mm}$ to control box.
 Attention: Do not make tight arches! /
 Kabelrohr $\varnothing 80\text{mm}$ zum Schaltschrank.
 Achtung: Keine engen Bögen!

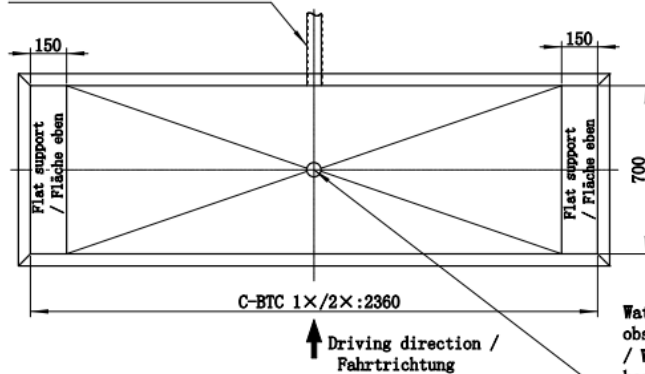

Quality of concrete min.
 C20/25 (EN 206-1) /
 Betonqualität min.
 C20/25 (EN 206-1)

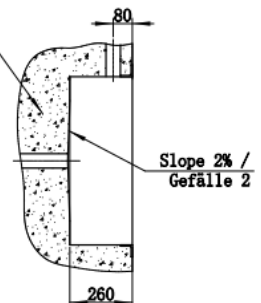

Water drainage on request. Please
 observe building regulations of drainage!
 / Wasserablauf nach Anforderung. Bitte
 beachten Sie die Bauvorschriften für die
 Entwässerung!

- COSBER C-BTC 3x:

Cable conduit Ø80mm to control box.
Attention: Do not make tight arches! /
Kabelrohr Ø80mm zum Schaltschrank.
Achtung: Keine engen Bögen!

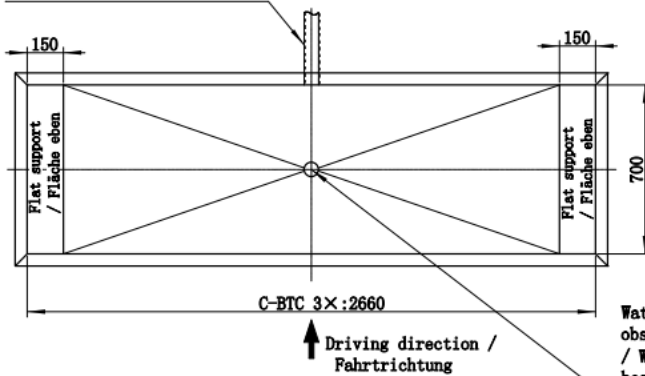

Quality of concrete min.
C20/25 (EN 206-1) /
Betonqualität min.
C20/25 (EN 206-1)

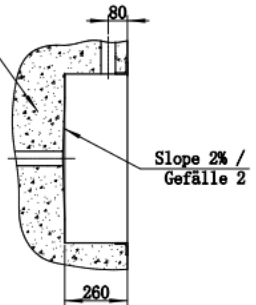

Water drainage on request. Please
observe building regulations of drainage!
/ Wasserablauf nach Anforderung. Bitte
beachten Sie die Bauvorschriften für die
Entwässerung!

- COSBER C-BTC 4x:

Cable conduit Ø80mm to control box.
Attention: Do not make tight arches! /
Kabelrohr Ø80mm zum Schaltschrank.
Achtung: Keine engen Bögen!

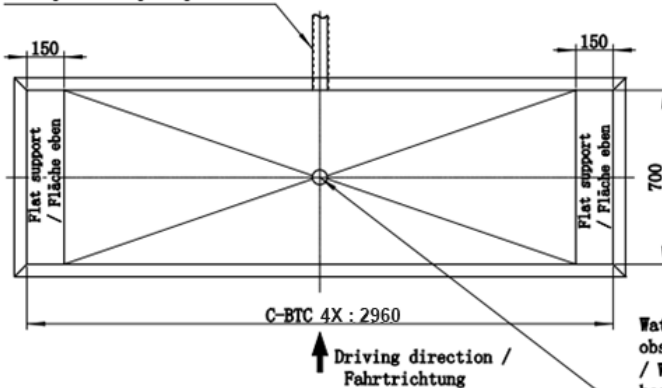

Quality of concrete min.
C20/25 (EN 206-1) /
Betonqualität min.
C20/25 (EN 206-1)

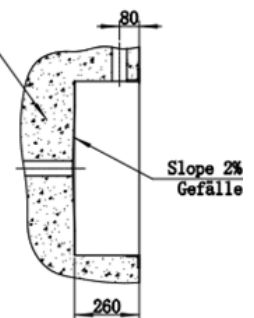

Water drainage on request. Please
observe building regulations of drainage!
/ Wasserablauf nach Anforderung. Bitte
beachten Sie die Bauvorschriften für die
Entwässerung!

- Please check the length, width and depth of the foundation pit, outlet hole location and other dimensions according to the requirements found on the product foundation drawing. Both sides in the bottom of the foundation pit are flat, and the middle of the foundation pit has a 2% slope to the water hole. The wire tube should never be blocked. Infrastructure and concrete used must meet all requirements and be fully solidified.

| Model | Roller length (mm) | Length (mm) | Width (mm) | Height (mm) |
|----------|--------------------|-------------|------------|-------------|
| C-BTC 2X | 700 | 2320 | 660 | 240 |
| C-BTC 3X | 850 | 2620 | 660 | 240 |
| C-BTC 4X | 1000 | 2920 | 660 | 240 |

2.1.3 Foundation frames

Mounting diagram of foundation frame:

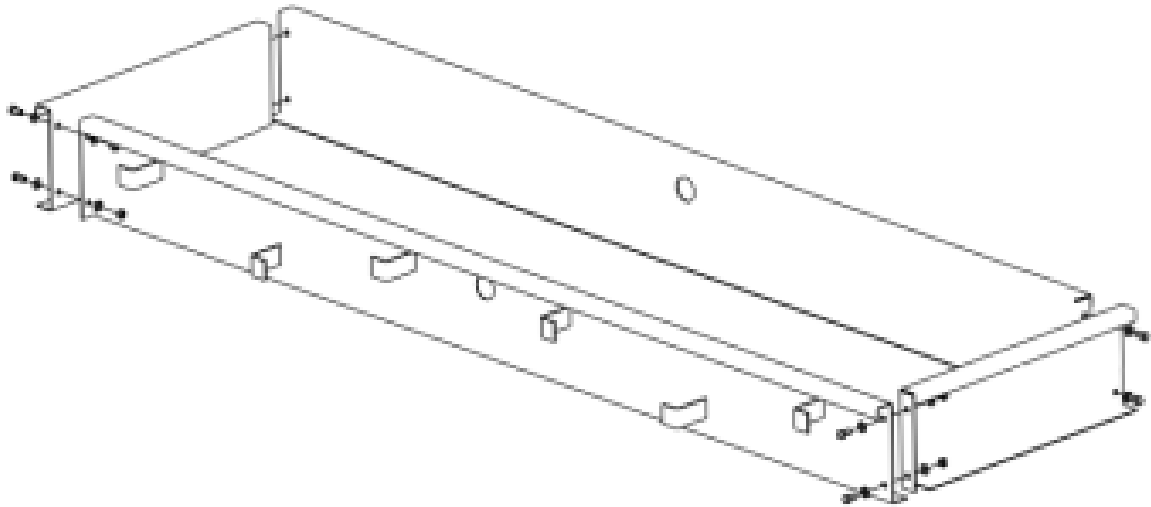

Mounting diagram of edge protection frame

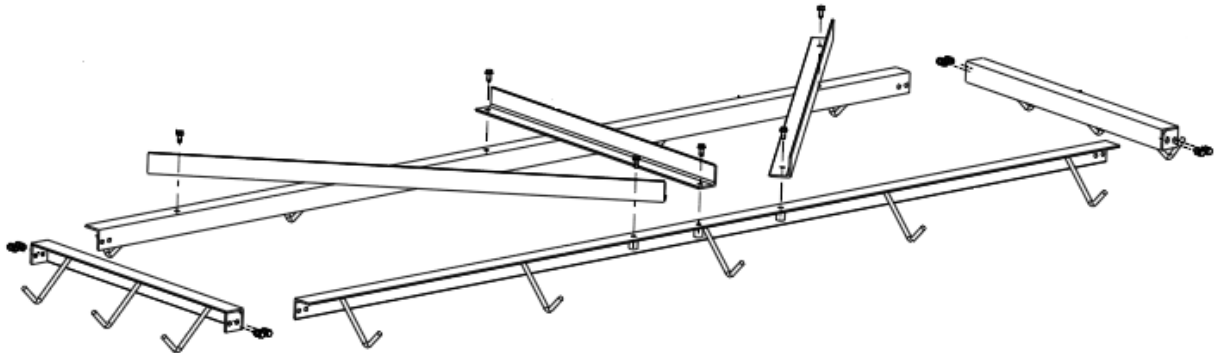

2.1.4 Installation location

- The equipment and its components should be installed in the most suitable position within the workshop.
- Always consider the needs of your customers, federal or provincial regulations, safety requirements, operation, and technical requirements and use requirements during the position layout process.

2.1.4.1. Installation layout with Analog-Display

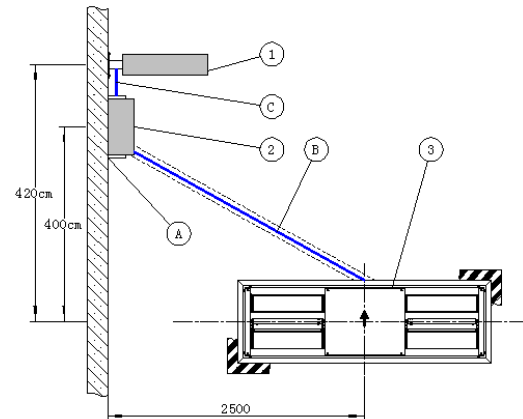
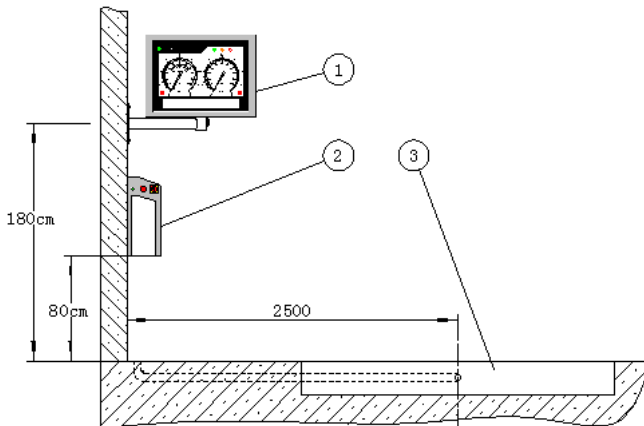

| No. | Name |
|-----|----------------|
| 1 | Analog-Display |
| 2 | Control box |
| 3 | Brake tester |

| No. | Name | Connection |
|-----|--------------------------|---|
| A | Power cable | Electric control box <=> Main power switch (provided by customer) |
| B | Power cable, signal wire | Electric control box <=> Brake tester |
| C | Signal wire | Electric control box <=> Analog-Display |

2.1.4.2. Installation layout with PC connection

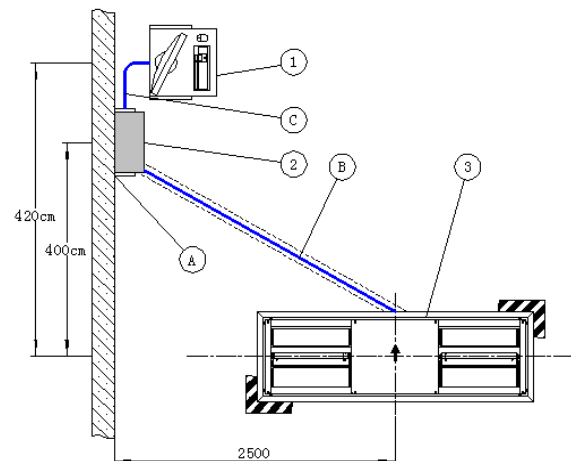
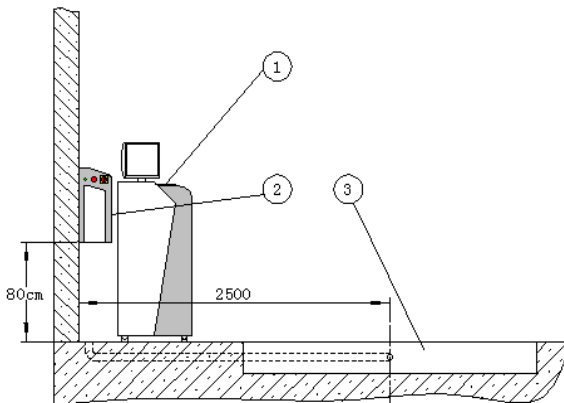

| No. | Name |
|-----|------------------------------------|
| 1 | PC and computer cabinet (optional) |
| 2 | Control box |
| 3 | Brake tester |

| No. | Name | Connection |
|-----|--------------------------|---|
| A | Power cable | Electric control box <=> Main power switch (provided by customer) |
| B | Power cable, signal wire | Electric control box <=> Brake tester |
| C | Signal wire | Electric control box <=> PC |

2.1.5 Power and wiring requirements



WARNING!

- The main power switch must meet all national standards and safety requirements. It must also meet the power utilization requirements of the equipment.
- The main power switch must be provided with safe grounding that meets all national standards and safety requirements. Grounding is especially important for safe operation and overall equipment stability.
- For installation locations with large fluctuations in power grid voltage, a lightning protection or surge protection device should also be installed on the power supply.
- Before connecting the power cable, make sure that the main power switch is in the OFF position.
- The personnel must be equipped with insulated gloves and insulated boots during construction.

2.2 Brake tester installation.

2.2.1 Adjustment of brake tester height

- Brake testers without weight scale.

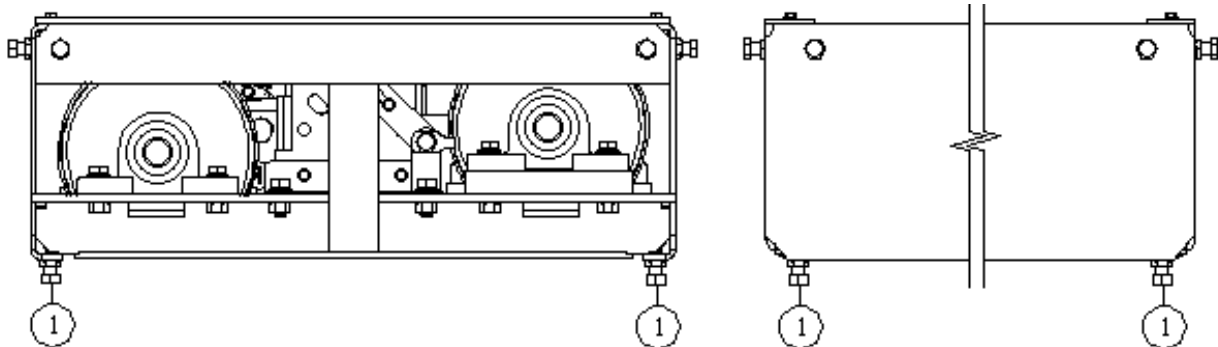

- Brake testers with weight scale.

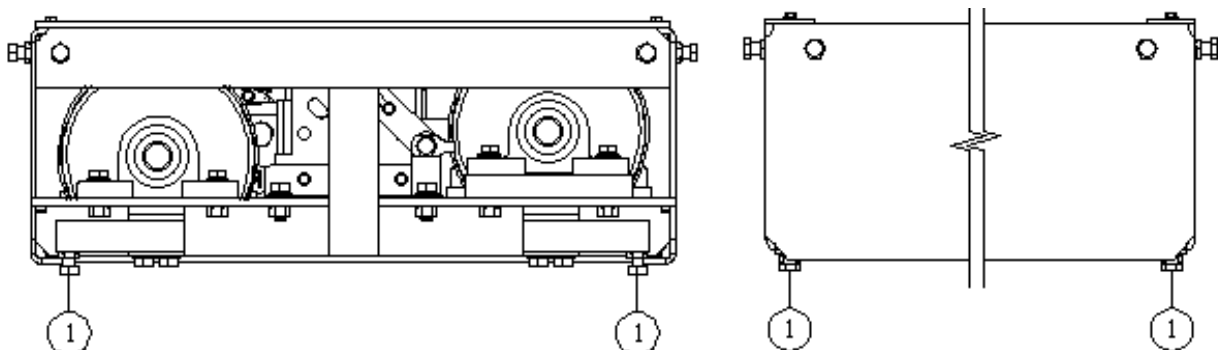

- Height compensation plates

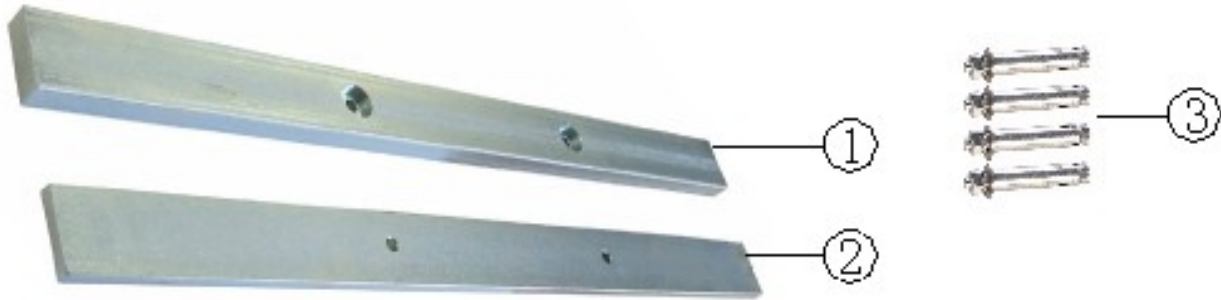

| No. | Item No. | Name | Quantity |
|-----|---------------|--------------------------|----------|
| 1 | 20.02.02.0013 | Compensation plate 20 mm | 2 |
| 2 | 20.02.02.0014 | Compensation plate 10 mm | 2 |
| 3 | 70.05.16.1209 | Anchor bolt M12x120 | 8 |

- Before installation, measure the depth of all four corners in the foundation pit.
- If the depth of the foundation pit is incorrect, smaller height deviations can be adjusted by adjusting the Screw. After adjusting the height, you must tighten the locknut on the adjustment Screw. Large height deviations can be adjusted via the installation of an adjustment plate; 2 pieces 20mm thick and 2 pieces of 10mm thick are available and can be selected according to the actual situation. The adjustment plate can be placed underneath the adjusting Screw and fixed to the foundation pit with expansion bolts.
- After installation in the foundation pit, the four adjustment Screws must be forced evenly.

2.2.2 Cable duct

- Use the threading device to pass the power cable and signal wire of the brake tester through the wire threading pipe and connect them to the outlet on the control cabinet.
- Due to the limited space available, install the threading device before the equipment is placed into the pit.

2.2.3 Lifting the brake tester

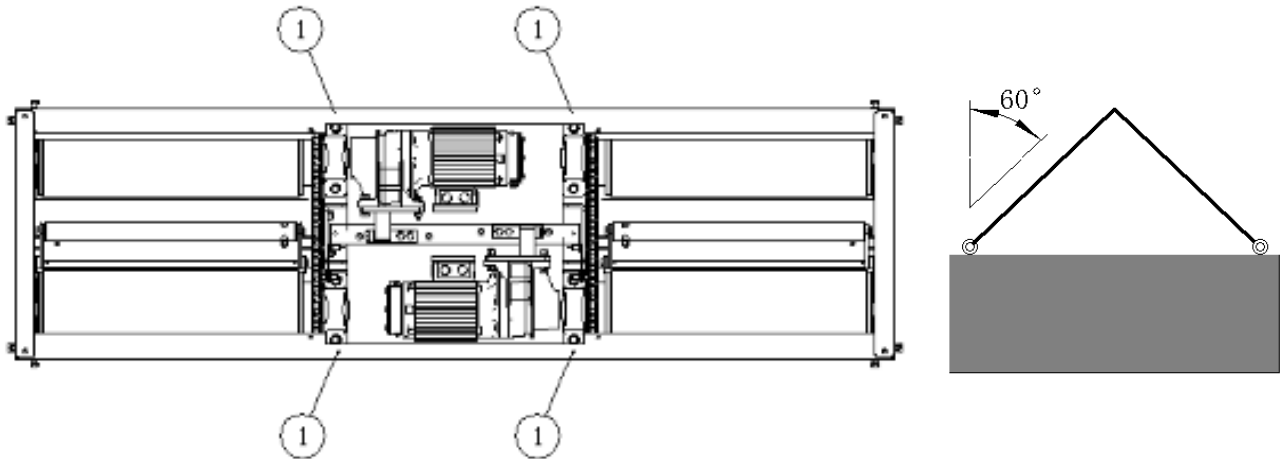

- Remove the middle cover of the brake tester.
- Install four M12 eye screw properly as shown in the illustrated position.
- Hook the eye screw with the lifting rope and hang on the lifting equipment or forklift arm.
- The lifting capacity of lifting equipment or forklift must be more than 600kg.
- The inclination of lifting rope must be smaller than 60°.
- The lifting process must meet the safe operation requirements of the lifting equipment or forklift.
- Lower the brake tester slowly into the foundation pit.
- Make sure that the brake test bench is oriented in the right direction.
- After inserting the brake test bench, use a water level to check whether the test bench is positioned horizontally. If necessary, adjust the alignment by lifting and adjusting the brake test bench again.



ALWAYS PAY ATTENTION TO SAFETY AND AVOID INJURY DUE TO FALLING OBJECTS DURING THE LIFTING AND TRANSPORT PROCESS!

WARNING!

- Personnel must comply with the applicable requirements for personal protective equipment (PPE) during installation.
- No person is allowed to be under the lifted goods.

2.2.4 Fixing the brake tester

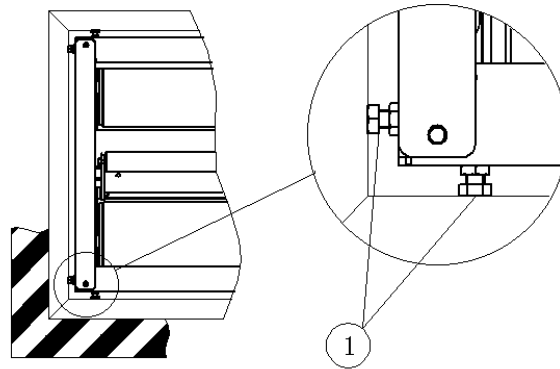

- After confirming that the brake tester has been placed properly, adjust the eight top edge screws so that the gap between the brake tester and the foundation is even.
- For brake testers without a weight measurement function, the top edge bolts must extend from the foundation pit to fix the brake tester.
- For brake testers with weighing function, the bolt head in the top edge should not touch the foundation pit, and the bolts should not carry load, or else it will affect the weighing accuracy.
- After adjusting the top edge bolts, the nuts must be locked.

2.3 Installation of control box

2.3.1 Wall mounting

2.3.1.1. Wall mounting components

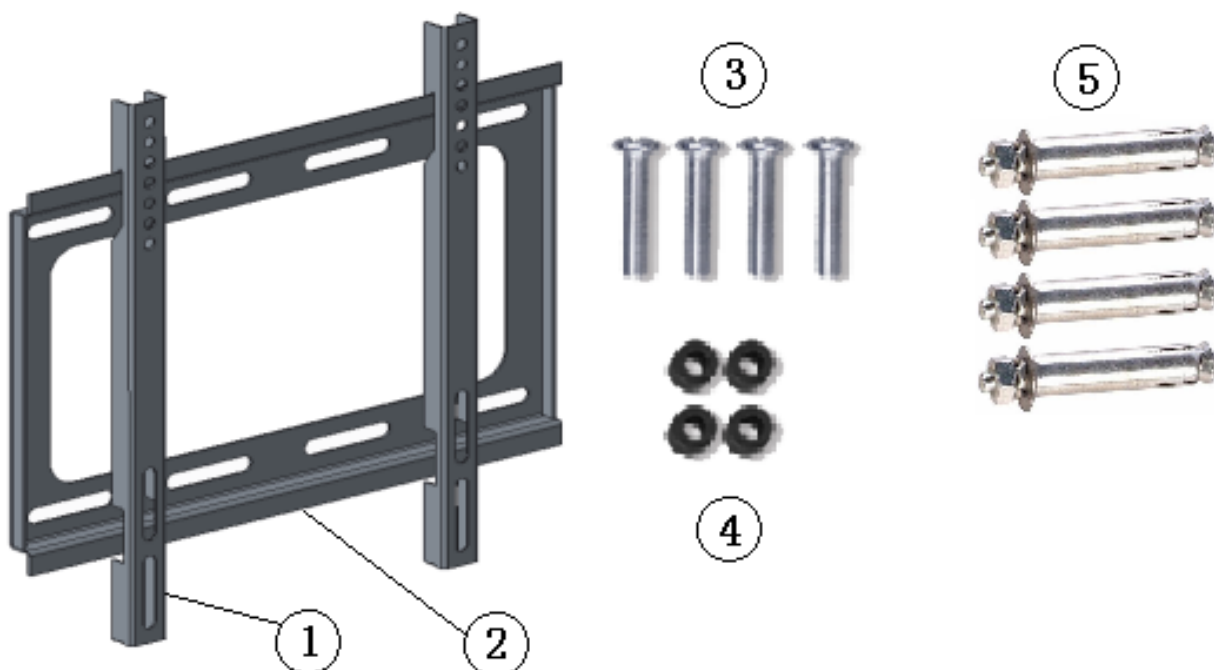

| No. | Item No. | Name | Quantity |
|-----|----------------------|---------------------------|----------|
| | 20.02.01.9917 | Wall Mounting Kit | |
| 1 | | Profile bar | 2 |
| 2 | | Bracket | 1 |
| 3 | | Screws M6x30 | 4 |
| 4 | | Insulating piece | 4 |
| 5 | 70.05.16.0806 | Mounting screws M8 | 4 |

2.3.1.2. Installation instructions

- Use the mounting hole on the bracket panel as a template. Drill 4 holes in the wall with appropriate drill bit to install the expansion bolts.
- Install the bracket panel on the wall, tighten the four expansion bolts, and fix the bracket panel.

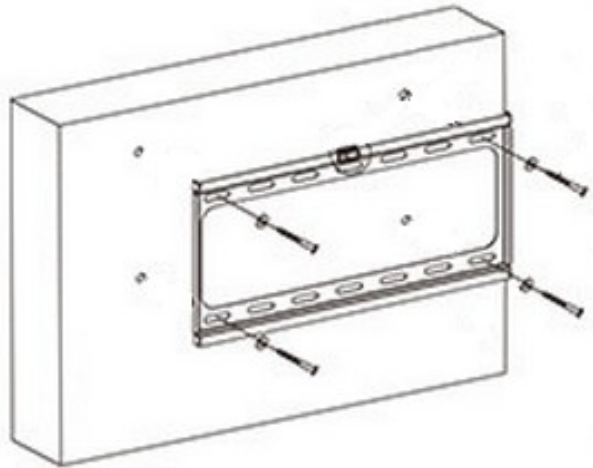

- Use M6x30 screws and the isolation column to install the flat arm to the back of the control box.

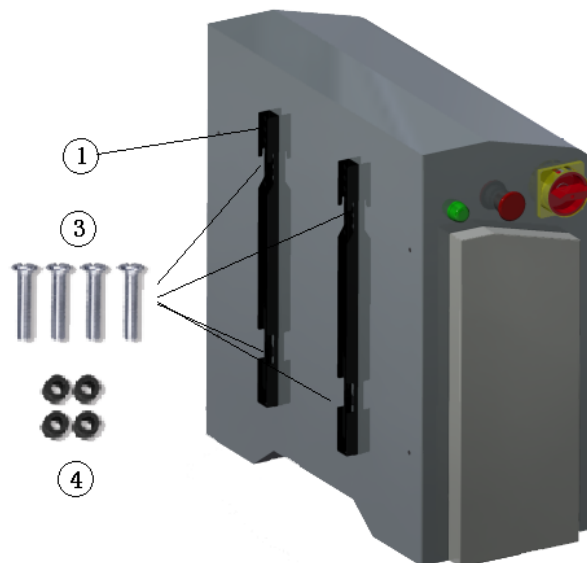

- Clamp the hook of the two hanging arms from the top down into the bracket panel and maintain the level.

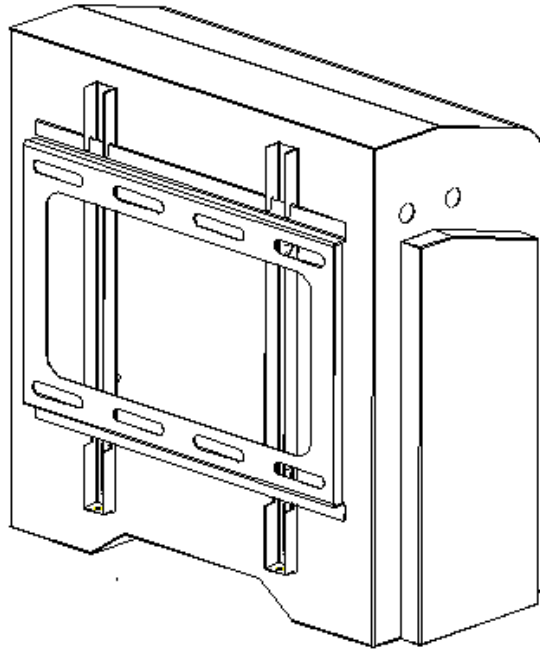

- Tighten the anti-slip screws to prevent the bracket from sliding.



NOTE!

- During drilling and installation, the operator should always wear protective glasses and a dust mask; if an electric drill is used, the operator should always take electrical protection measures.
- Be aware that objects can fall at any time while working! Personnel must comply with the applicable requirements for personal protective equipment (PPE) during installation.

2.3.2 Installation of column

2.3.2.1. Mounting drawing of column

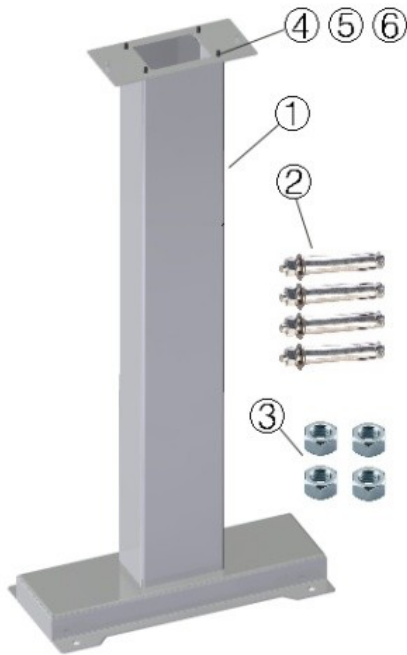

| No. | Item Num. | Name | Quantity |
|-----|----------------------|----------------------------------|----------|
| | 20.02.15.1002 | Components for the Column | |
| 1 | 20.02.01.9912 | Column | 1 |
| 2 | 70.05.16.1209 | Mounting screws M10 | 4 |
| 3 | 70.05.17.0601 | Hexagon Nut M6 | 4 |
| 4 | 70.05.16.0605 | Hexagon Bolt M6x30 | 4 |
| 5 | 70.05.18.0601 | Disc 6 | 4 |
| 6 | 70.05.18.0602 | Spring washer 6 | 4 |

2.3.2.2. Installation instructions

- Use the mounting hole on the column as a template. Drill 4 holes in the ground with the appropriate drill bit to install the expansion bolts.
- Tighten the four expansion bolts and fix the column to the ground; keep the column vertical during installation.
- Install the control cabinet on the column and fix with 4 hex nuts.

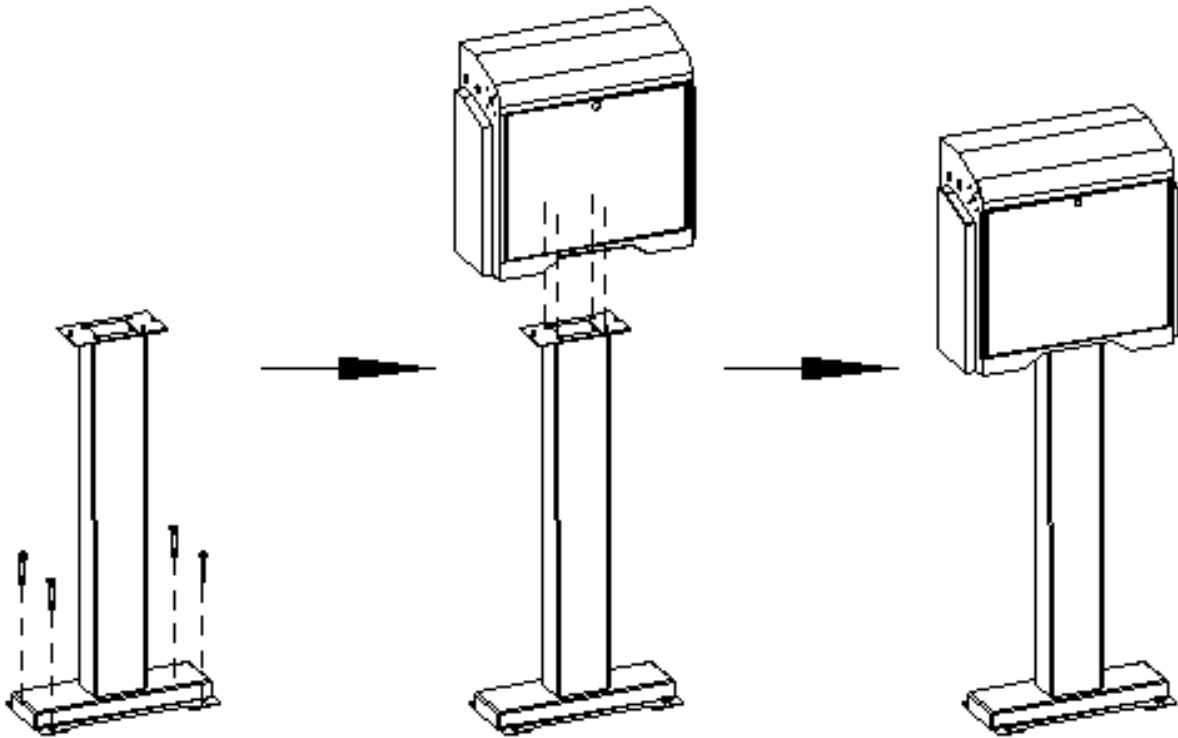

2.4 Installation of Analog-Display

The Analog-Display can be mounted on a wall mount or on a pedestal.

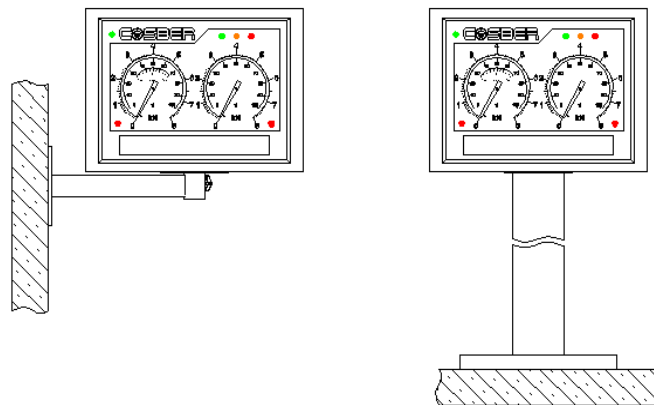

The Analog-Display includes the following components:

| No. | Art. No. | Description |
|-----|---------------|---|
| 1 | 20.02.15.2001 | Analog-Display 2 x 8 kN |
| 2 | 20.02.01.9908 | Wall mount (including mounting accessories) |
| 3 | 20.02.01.9913 | Column (including mounting accessories) |

2.4.1 Wall mounting

2.4.1.1. Swing arm description.

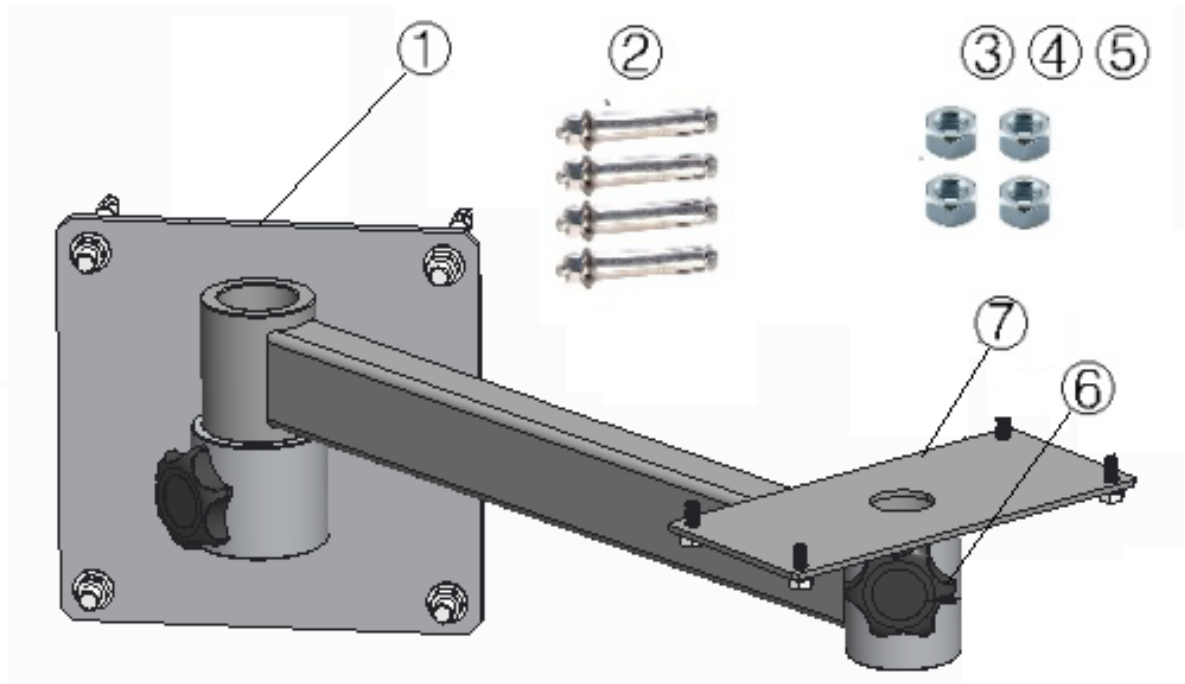

| No. | Art. No. | Description | Quantity |
|-----|---------------|---------------------|----------|
| 1 | 20.02.01.9922 | Wall bracket | 1 |
| 2 | 70.05.16.1209 | Mounting screws M10 | 4 |
| 3 | 70.05.17.0601 | Nut M6 | 4 |
| 4 | 70.05.18.0601 | Washer 6 | 4 |
| 5 | 70.05.18.0602 | Spring washer 6 | 4 |
| 6 | 70.05.19.0082 | Screws M8×10 | 1 |
| 7 | 20.02.01.9925 | Support plate | 1 |

2.4.1.2. Swing arm installation.

- Use the mounting hole on the wall bracket as a template. Drill 4 holes in the wall with the appropriate drill bit to install the expansion bolts.
- Tighten the four expansion bolts and fix the wall bracket to the wall.
- Install the pointer instrument on the wall bracket and fix with four hex nuts.
- Adjust the angle of the pointer instrument and tighten the star handle.

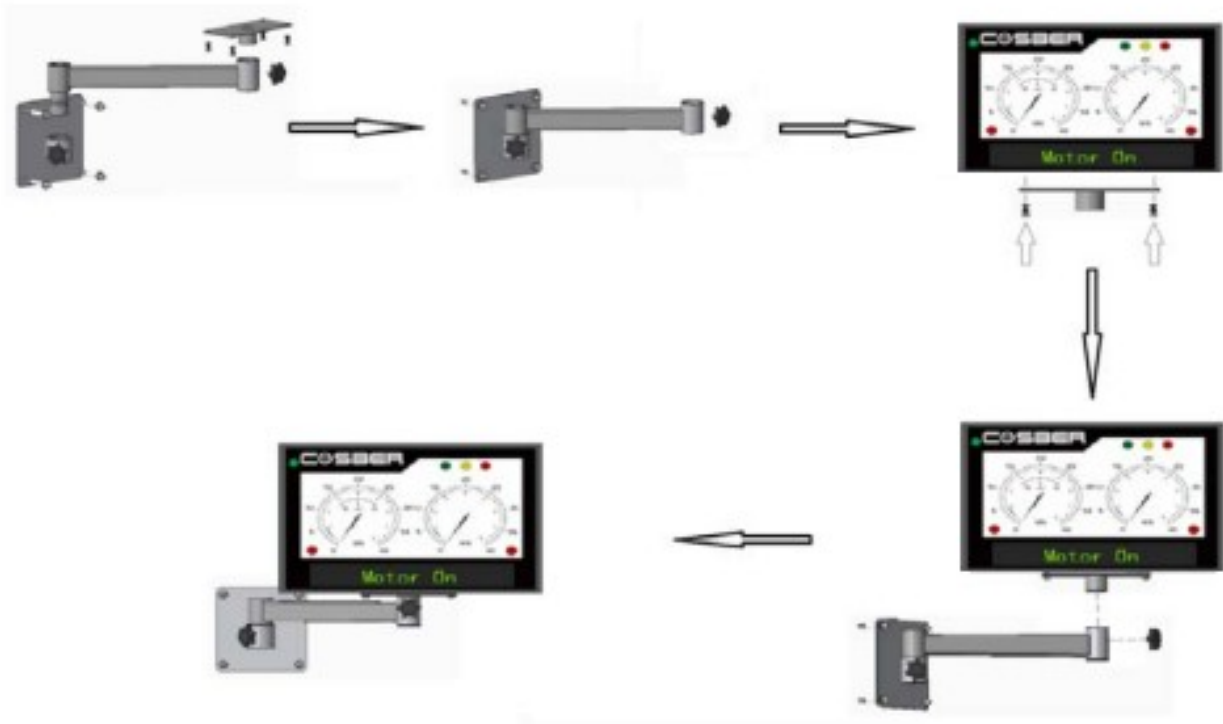

2.4.2 Column

2.4.2.1. Column description

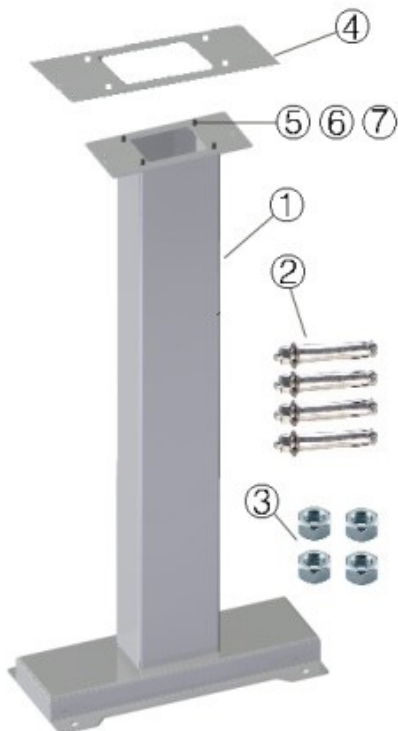

| No. | Item Num. | Description | Quantity |
|-----|-----------|-------------|----------|
|-----|-----------|-------------|----------|

All contents of this work are protected by copyright. Unless expressly stated otherwise, the copyright is held by Cosber GmbH
Subject to changes and errors.

| | 20.02.15.2002 | Components of the column | 1 |
|---|---------------|--------------------------|---|
| 1 | 20.02.01.9912 | Column | 1 |
| 2 | 70.05.16.1209 | Mounting screws M10 | 4 |
| 3 | 70.05.17.0601 | Hexagon Nut M6 | 4 |
| 4 | 20.02.01.9914 | Mounting plate | 1 |
| 5 | 70.05.16.0605 | Hexagon Bolt M6x30 | 4 |
| 6 | 70.05.18.0601 | Disc 6 | 4 |
| 7 | 70.05.18.0602 | Spring washer 6 | 4 |

2.4.2.2. Column installation

- Use the mounting hole on the column as a template. Drill 4 holes in the wall with the appropriate drill bit to install the expansion bolts.
- Tighten the four expansion bolts and fix the column to the ground; keep the column vertical during installation.
- Install the pallet above the column and insert the screw.
- Install the pointer instrument on the pallet and fix with four hex nuts.

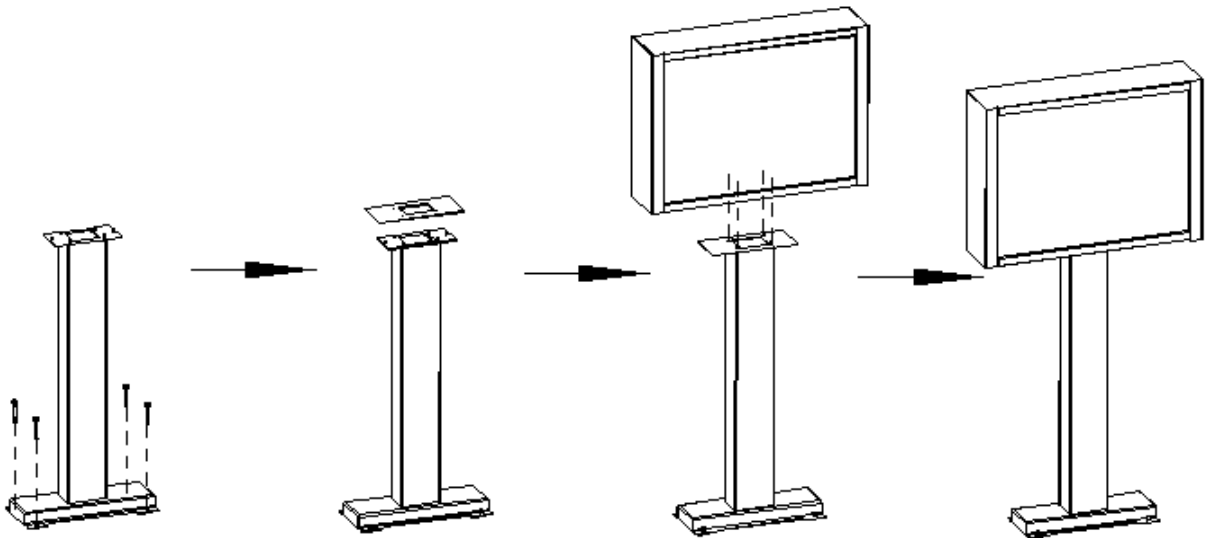

3 Control box



WARNING!

BEFORE CONNECTING THE POWER CABLE, MAKE SURE THAT THE MAIN POWER SWITCH IS IN OFF POSITION.

3.1 Control box description.

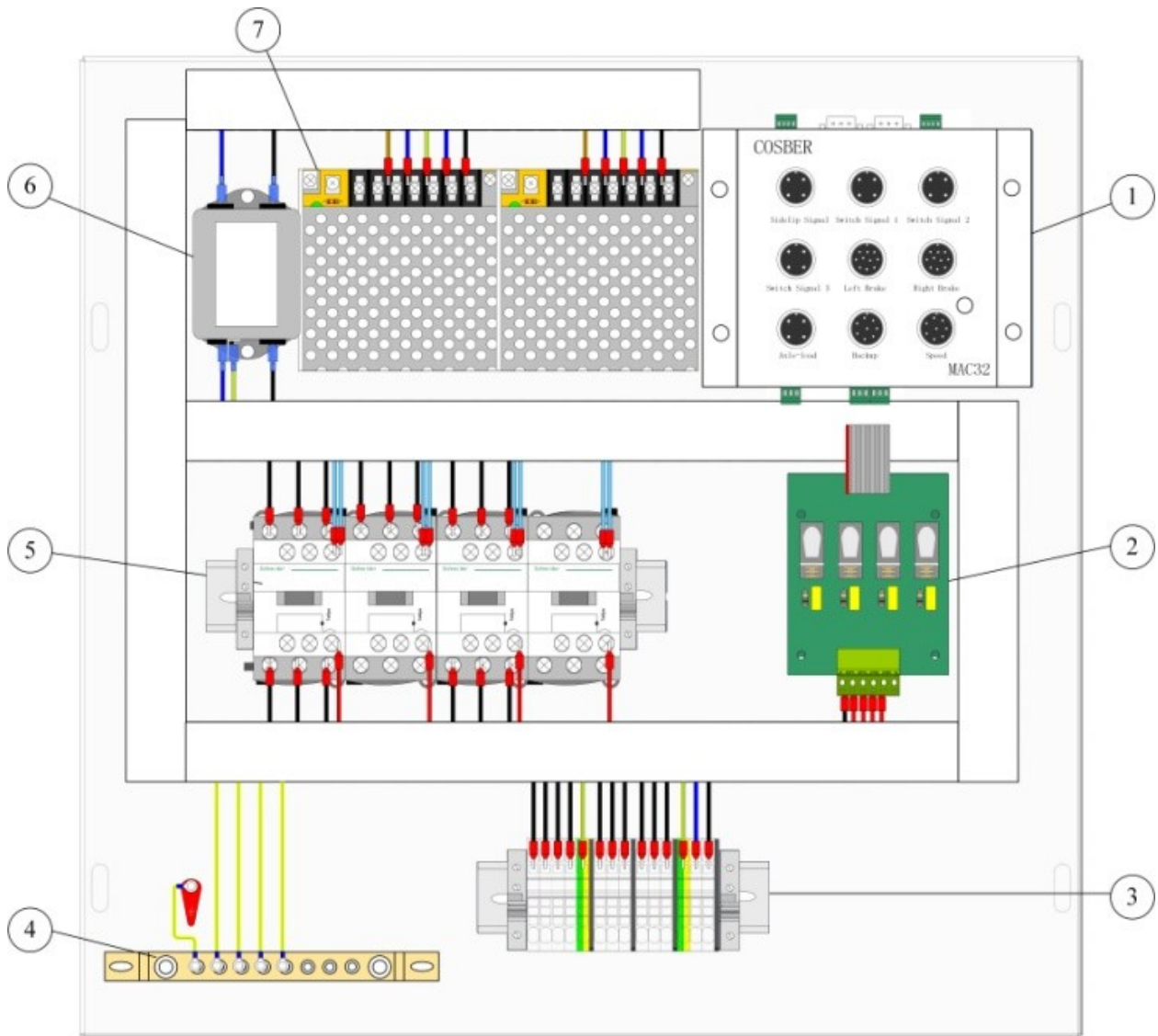

| No. | Description | Function |
|-----|------------------------|--|
| 1 | Main board box (MAC32) | The main control board controls motor rotation through the relay board. It also collects the sensor signal, converts it into test data, and displays the data through the instrument cabinet or computer |
| 2 | Relay board | Used to control on/off the AC contactor |
| 3 | Wiring terminal | Used to connect the load |
| 4 | Ground terminal | Used to connect to the ground |
| 5 | AC contactor | The AC contactor is controlled by the relay board for forward and reverse rotation of the left and right motors of the rack |
| 6 | Filter | This filters out interference and harmonics in the power supply |

| | | |
|---|------------------------|---|
| 7 | Switching power supply | Supplies power to the main control board, sensors, and other low-voltage components |
|---|------------------------|---|

3.2 Electric diagram

Two-wheel drive function

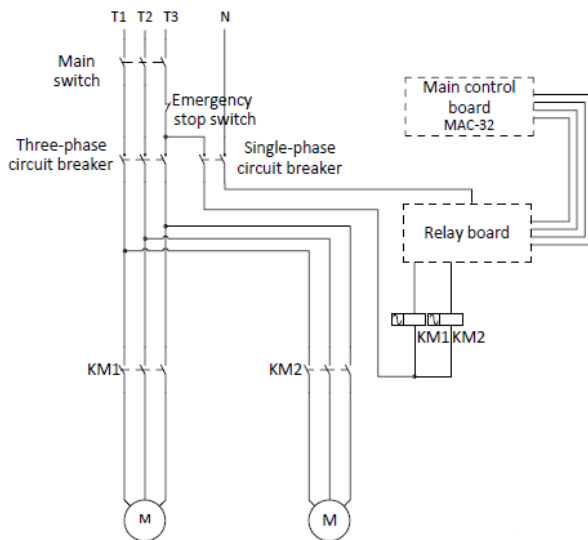

Four-wheel drive function

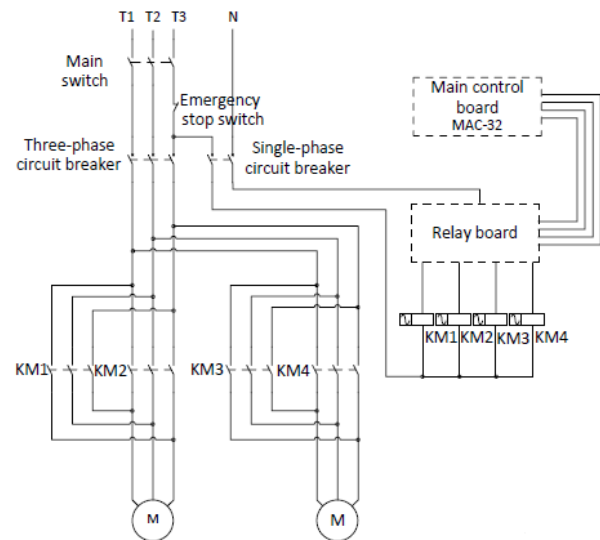

3.3 Electrical connection

3.3.1 Connecting the main power cable

Connect the power cable from the electric control cabinet to the on-site distribution cabinet. Note that it is necessary to connect the L1, L2, L3, N and PE lines according to the markings on the power cables.

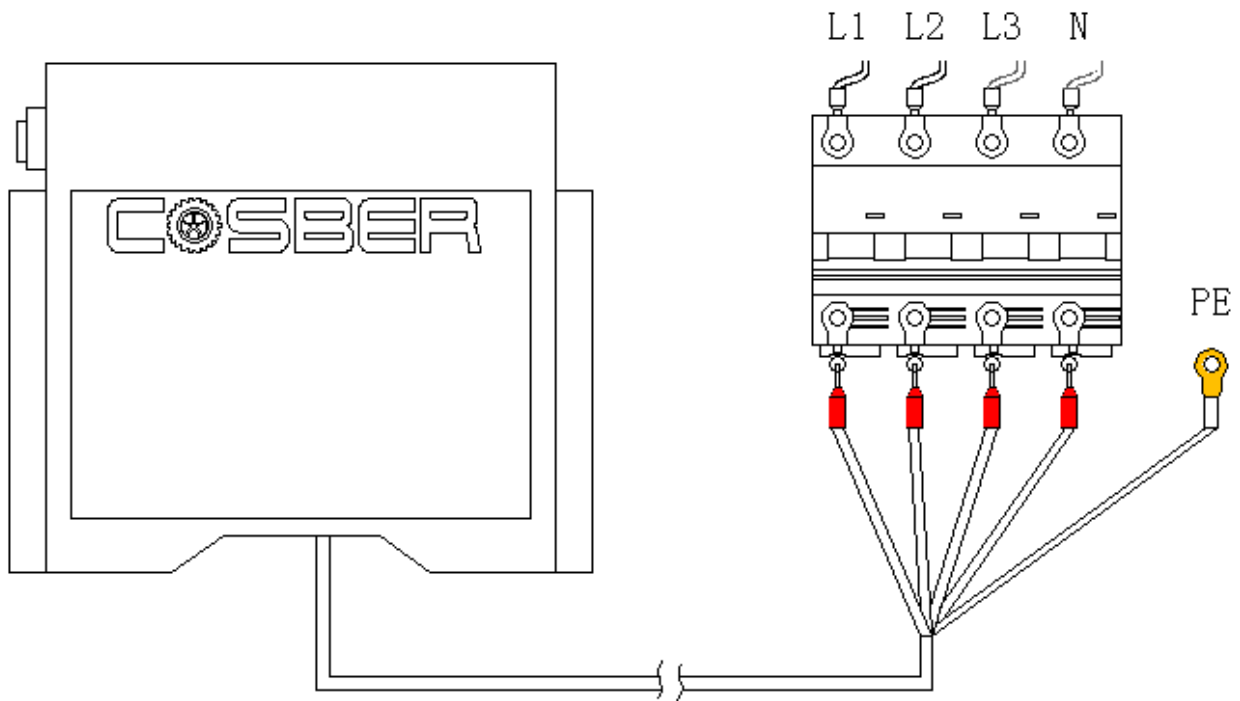

3.3.2 Connecting the brake test bench

3.3.2.1. Brake test bench wire description.

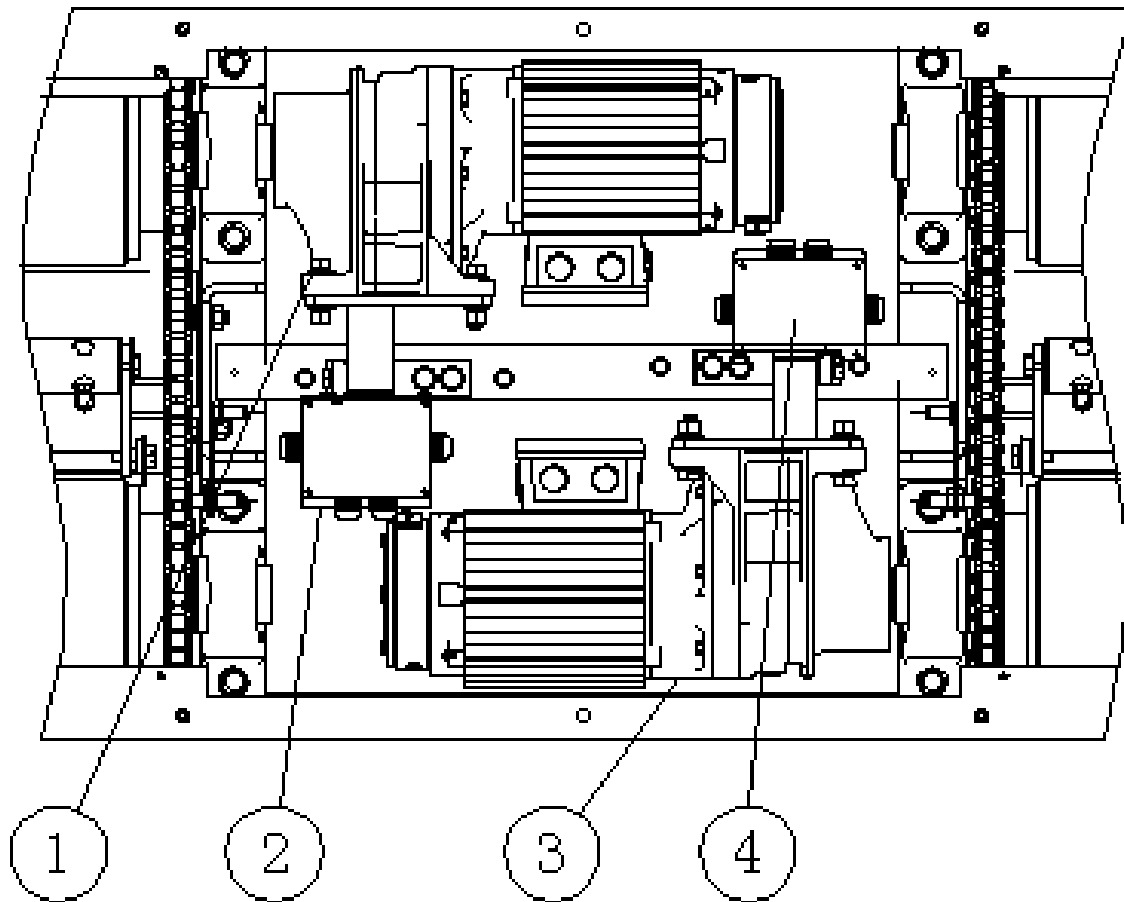

| No. | Description | Line |
|-----|--------------------|-------------------------|
| 1 | Left gear motor | Left motor power cable |
| 2 | Left Junction box | Left signal cable |
| 3 | Right gear motor | Right motor power cable |
| 4 | Right junction box | Right signal cable |

3.3.2.2. Connection the motor power cables

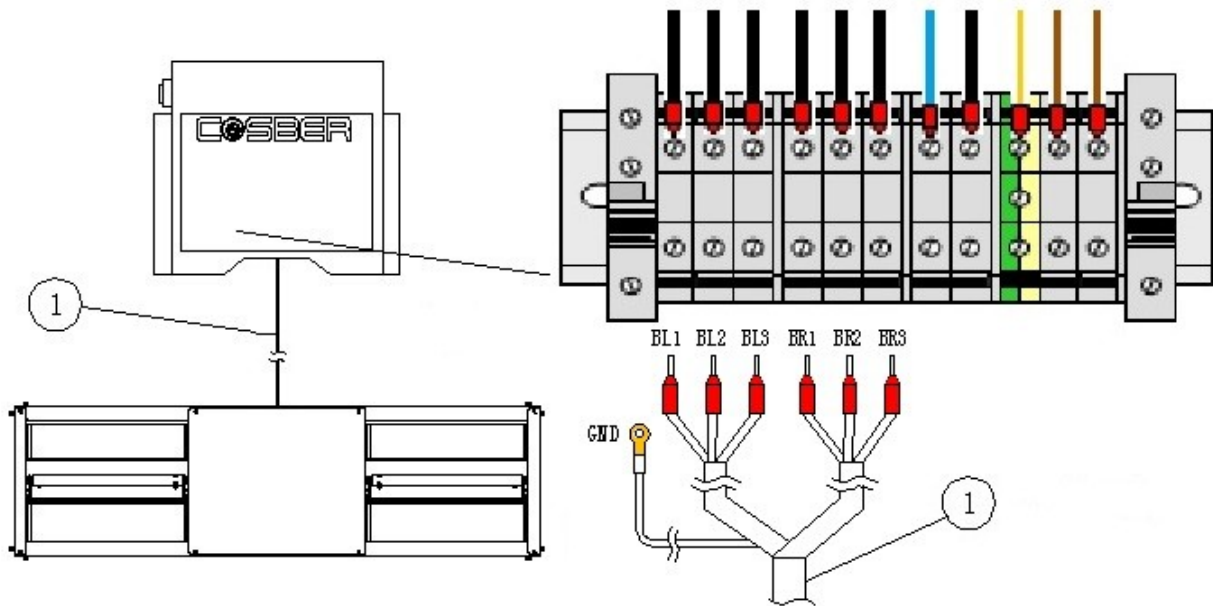

| No. | Description | Connection |
|-----|-------------------|---|
| 1 | Motor Power Cable | Wiring terminal BL1 BL2 BL3 BR1 BR2 BR3 GND |

- Connect the power cable marked “left motor cable” on the brake tester to BL1 BL2 BL3.
- Connect the power cable marked “right motor cable” on brake tester to BR1 BR2 BR3.
- The yellow-green ground wire must be connected to the ground terminal.

3.3.2.3. Connecting the signal cables

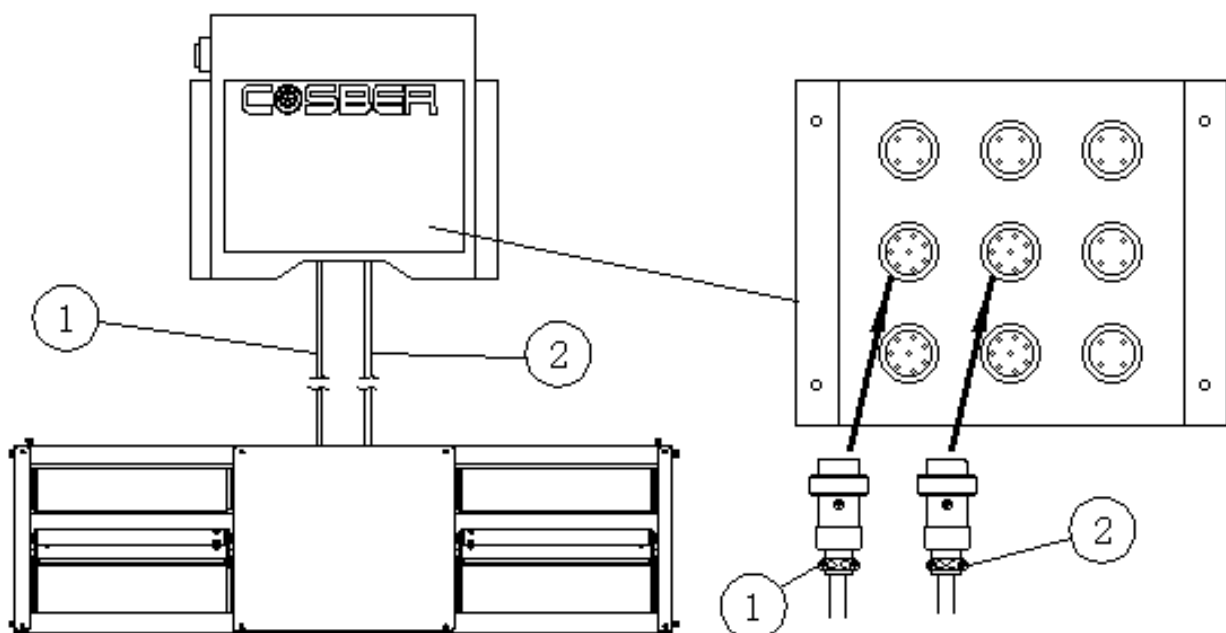

| No. | Description | Connection |
|-----|--|--------------------------|
| 1 | Left signal cable on the brake tester | Connect to "Left Brake" |
| 2 | Right signal cable on the brake tester | Connect to "Right Brake" |

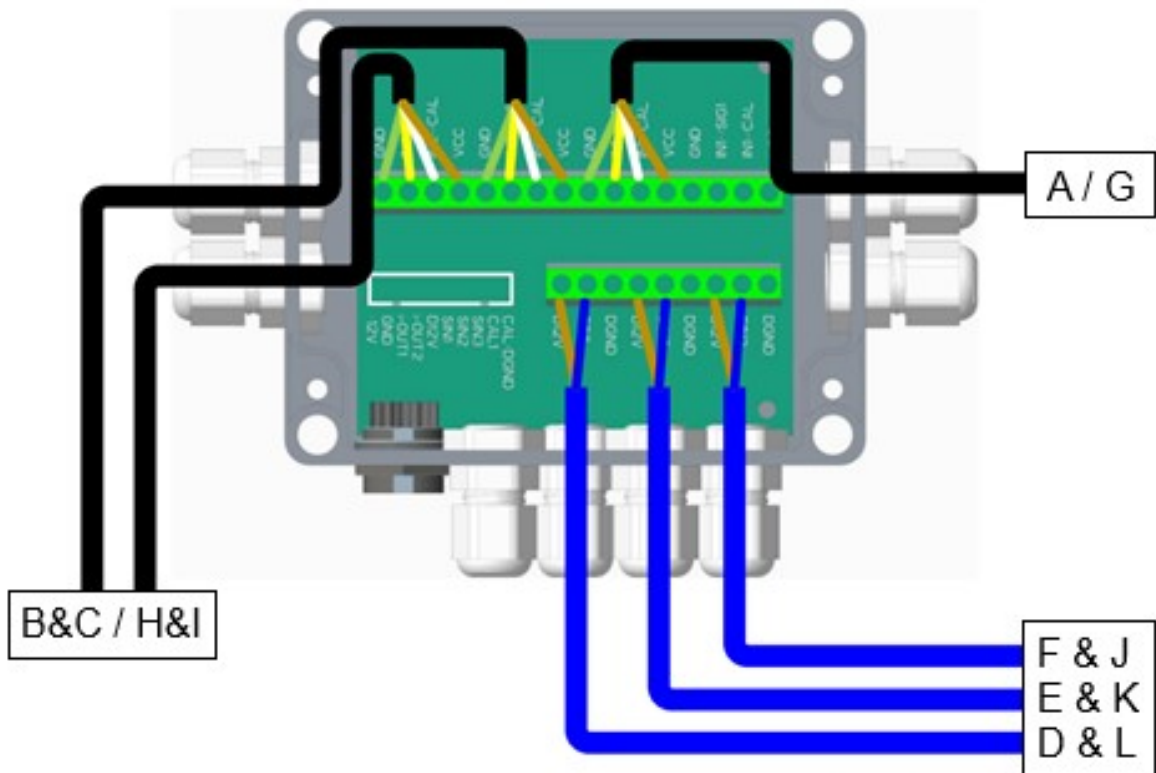
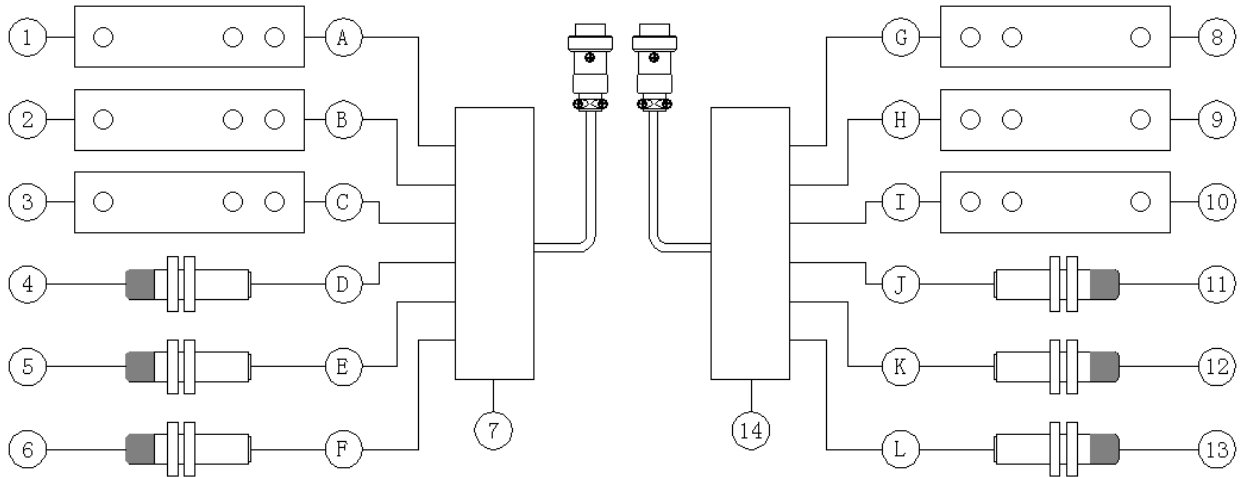

| No. | Description | Wire No. | Signal | Wire color |
|-----|-------------------|----------|-----------|------------|
| 1 | Left brake sensor | A | +12V | Brown |
| | | | CAL | White |
| | | | IN1-SIG 1 | Yellow |
| | | | GND | Green |

| | | | | |
|----|--|---|-----------|--------|
| 2 | Left weight sensor 1 | B | +12V | Brown |
| | | | CAL | White |
| | | | IN2-SIG 2 | Yellow |
| | | | GND | Green |
| 3 | Left weight sensor 2 | C | +12V | Brown |
| | | | CAL | White |
| | | | IN2-SIG 2 | Yellow |
| | | | GND | Green |
| 4 | Left small roller speed proximity switch | D | P12V | Brown |
| | | | SIN 1 | Blue |
| 5 | Left wheel presence proximity switch | E | P12V | Brown |
| | | | SIN 2 | Blue |
| 6 | Left big roller speed proximity switch | F | P12V | Brown |
| | | | SIN 3 | Blue |
| 7 | Left junction box | | | |
| 8 | Right brake sensor | G | +12V | Brown |
| | | | CAL | White |
| | | | IN1-SIG 1 | Yellow |
| | | | GND | Green |
| 9 | Right weight sensor 1 | H | +12V | Brown |
| | | | CAL | White |
| | | | IN2-SIG 2 | Yellow |
| | | | GND | Green |
| 10 | Right weight sensor 2 | I | +12V | Brown |
| | | | CAL | White |
| | | | IN2-SIG 2 | Yellow |
| | | | GND | Green |
| 11 | Right roller speed proximity switch | J | P12V | Brown |
| | | | SIG 1 | Blue |
| 12 | Right wheel presence proximity switch | K | P12V | Brown |
| | | | SIG 2 | Blue |
| 13 | Right wheel speed proximity switch | L | P12V | Brown |
| | | | SIG 3 | Blue |
| 14 | Right junction box | | | |

3.3.3 Connecting to a PC

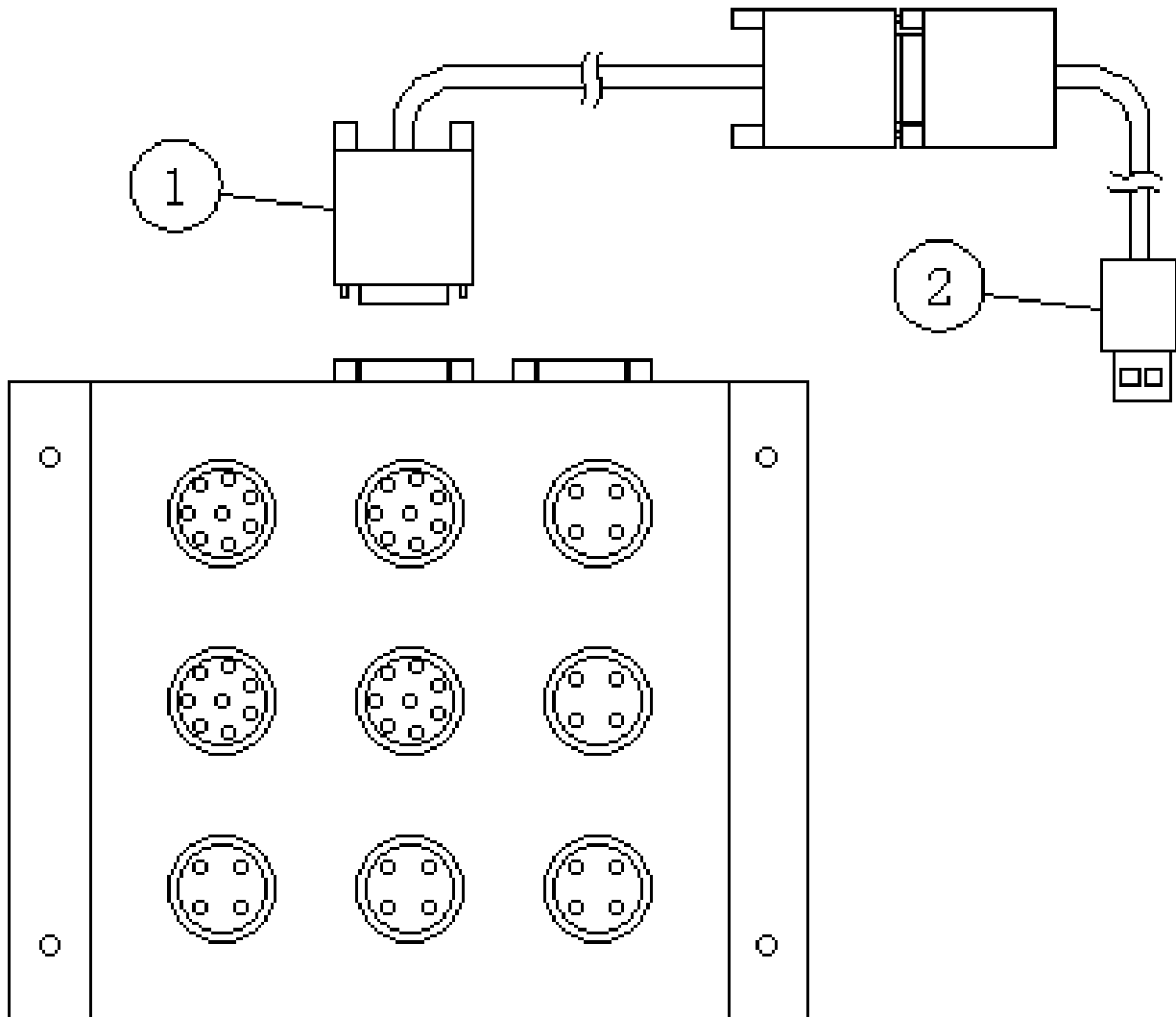

| No. | Description | Connection |
|-----|---------------------|-------------------------|
| 1 | Serial Cable | Main control board COM1 |
| 2 | Serial to USB cable | PC |

- Connect the plug of the serial cable to COM1 on the main control board of the control cabinet, connect the other end to the USB adapter cable, and connect the USB terminal to the PC.

4 Analog-Display

4.1 Analog-Display description

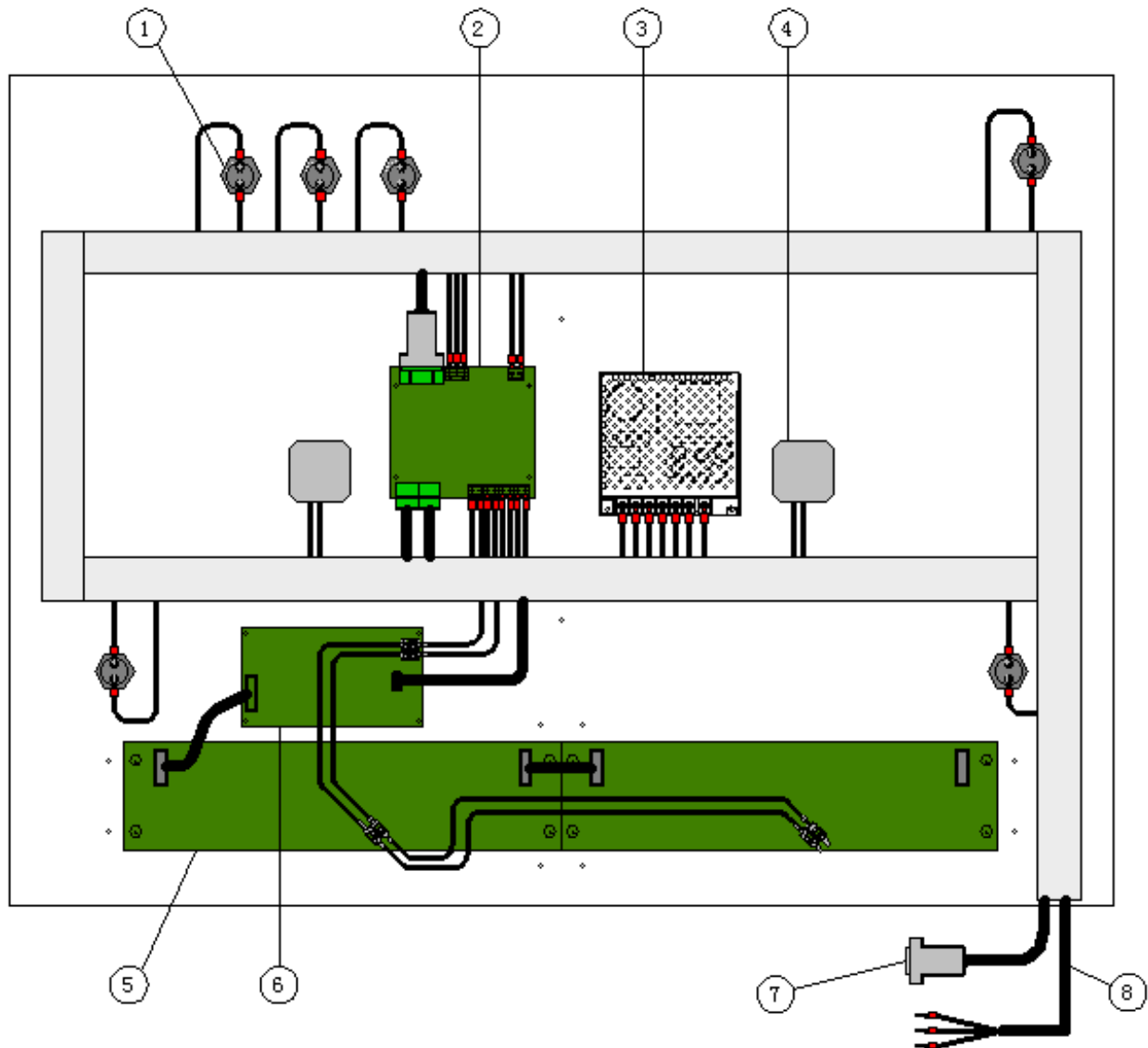

| No. | Description | Function |
|-----|------------------------|--|
| 1 | Indicator lights | Displays the working status of the instrument cabinet |
| 2 | Main control board | Processing data, and displaying test results |
| 3 | Switching power supply | Supply operating power |
| 4 | Step motors | Move the display board pointers |
| 5 | LED display unit | Displays test results |
| 6 | Serial signal cable | Transfers data and connects to the main control board of the control cabinet |
| 7 | Power cable | Connects the power supply to the terminal of the control cabinet |
| 8 | Indicator lights | Displays the working status of the instrument cabinet |

4.2 Electrical connection

4.2.1 Connecting the power cable

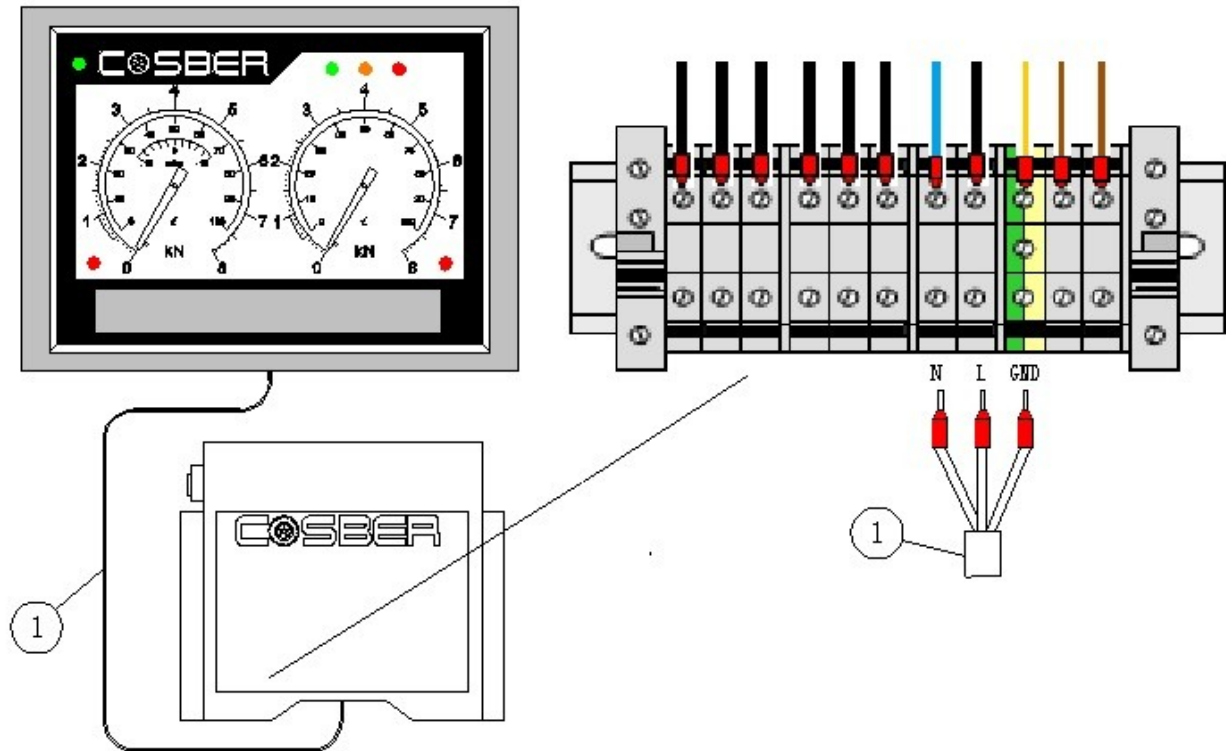

| No. | Description | Connection |
|-----|-------------|----------------------------------|
| 1 | Power cable | Control cabinet terminal N L GND |

- Connect the power cable from the pointer instrument cabinet to the terminal in the control cabinet. Note: it is necessary to connect the N, L, and GND lines according to the markings on the power cable.

4.2.2 Connection the signal cable

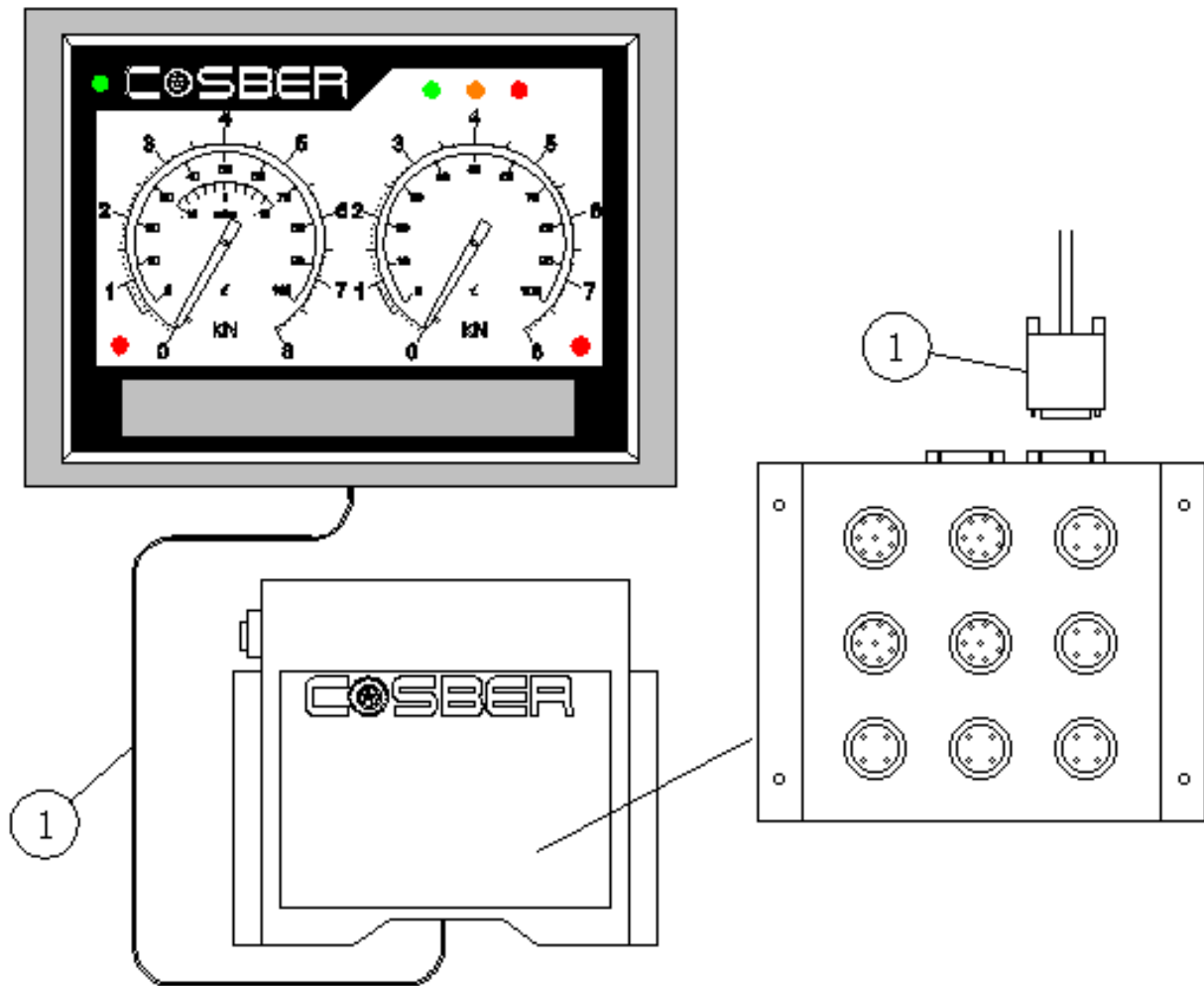

| No. | Description | Connection |
|-----|-------------|--------------------|
| 1 | Signal wire | Control board COM2 |

- Connect the plug on the signal cable to the main control board on the pointer instrument and then connect it to COM2 on the control board of the control cabinet.

5 Start

5.1 Installation checklist

- Before starting the device for the first time, check and make sure that all the installations have been finished correctly.
- Before checking the wiring, make sure that the main power switch is disconnected.

- (1) Check if all the devices and accessories to be installed are complete.
- (2) Check if acceptable circuit breakers are available on the installation site.
- (3) Check if all devices have been installed correctly.

- (4) Check if the motor power cord of the brake tester has been properly connected to the terminal of the control cabinet.
- (5) Check if the signal line of the brake tester has been properly connected to the main control board of the control cabinet.
- (6) Check if the main power cord of the control cabinet has been properly connected to the circuit breaker.
- (7) Check if the grounding wire is connected.
- (8) Check if the serial signal cable on the main control panel of the control cabinet is properly connected to the USB of the PC.
- (9) Check if the power cord of the pointer instrument is connected to the terminal of the control cabinet.
- (10) Check if the serial signal line of the pointer instrument has been properly connected to the main control board of the control cabinet.

5.2 Check by starting.



BEWARE OF ELECTRIC SHOCK WHEN STARTING THE MAIN POWER SWITCH; IF ELECTRIC SHOCK OR ELECTRIC LEAKAGE OCCURS, DISCONNECT THE POWER SWITCH IMMEDIATELY.

WARNING!

- (1) Turn on the power switch of the control cabinet, and check if the power indicator light is lit.
- (2) Turn on the three-phase circuit breaker switch and single-phase circuit breaker switch in the control cabinet, and check if the internal circuit of the control cabinet is normal.
- (3) When the power is turned on, check if all the lights on the pointer instrument are on, if the pointer is rotating, and if the screen displays. After starting, the pointer returns to the original position, the power indicator light turns on, and other lights turn off.
- (4) Run the software program, and check if the motor rotation is correct.
- (5) Run the software program, and check if the device signal is correct.



MAKE SURE THAT ALL DEVICES ARE INSTALLED AND WIRED CORRECTLY BEFORE USING.

ATTENTION!

6 Software system

6.1 Installation of the program

1. Open the installer and click on NEXT



2. Click on NEXT

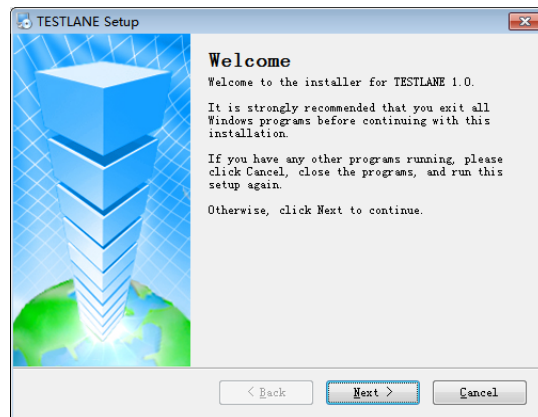

3. Select your language and click on NEXT

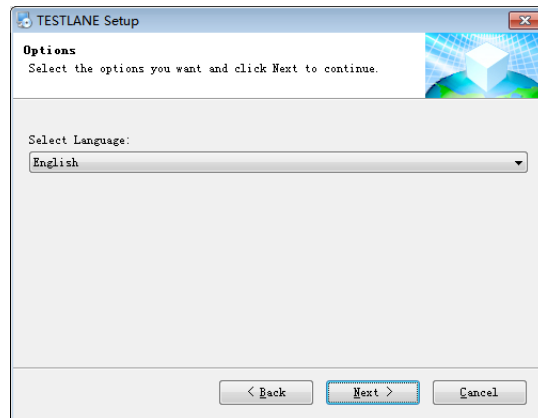

4. Enter your user details and click on NEXT

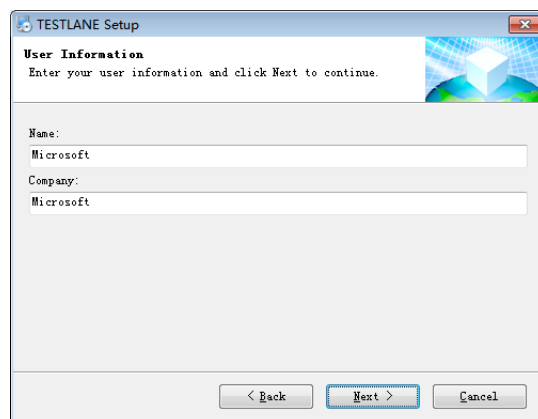

5. Select your model and click on NEXT

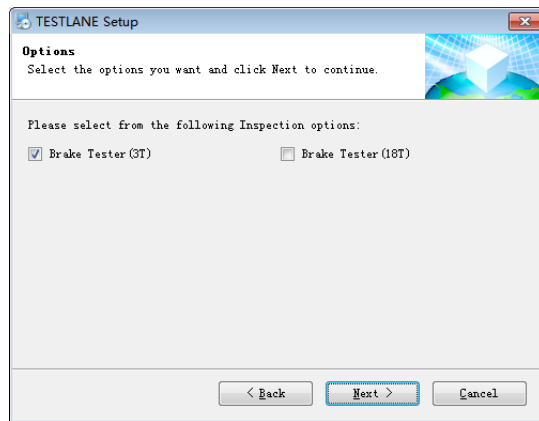

6. In the directory, select the folder for installation and click NEXT



7. Confirm all the details before starting the installation and click on NEXT

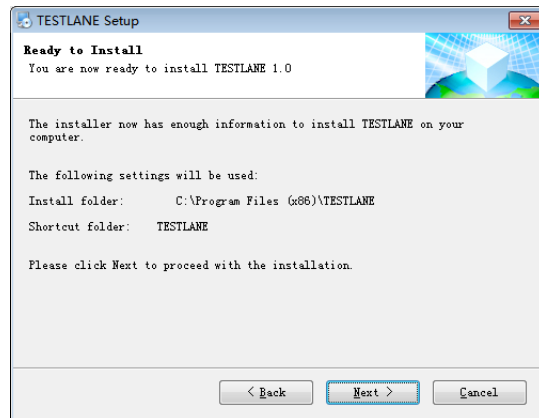

8. Wait for the progress bar to go through and then click Finish

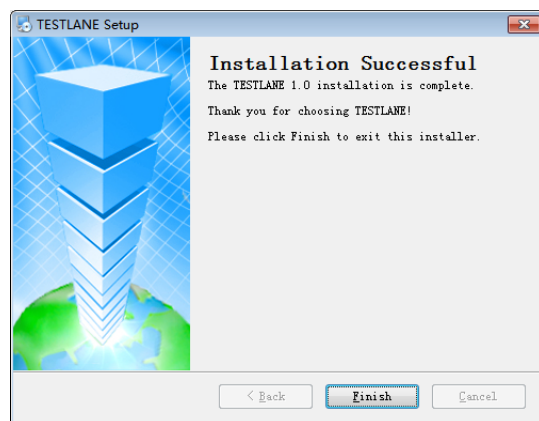

COSBER



Cosber GmbH
Lise-Meitner-Str. 3
82152 Krailling
GERMANY

Phone: +49 (0) 89 262 07 66-00
Fax: +49 (0) 89 262 07 66-60
E-mail: info@cosber.de
Web: www.cosber.de

